

HOMO BOHEMIANS

**Figure 7. Spending per capita and as a proportion of GDP are lower than the EU average**

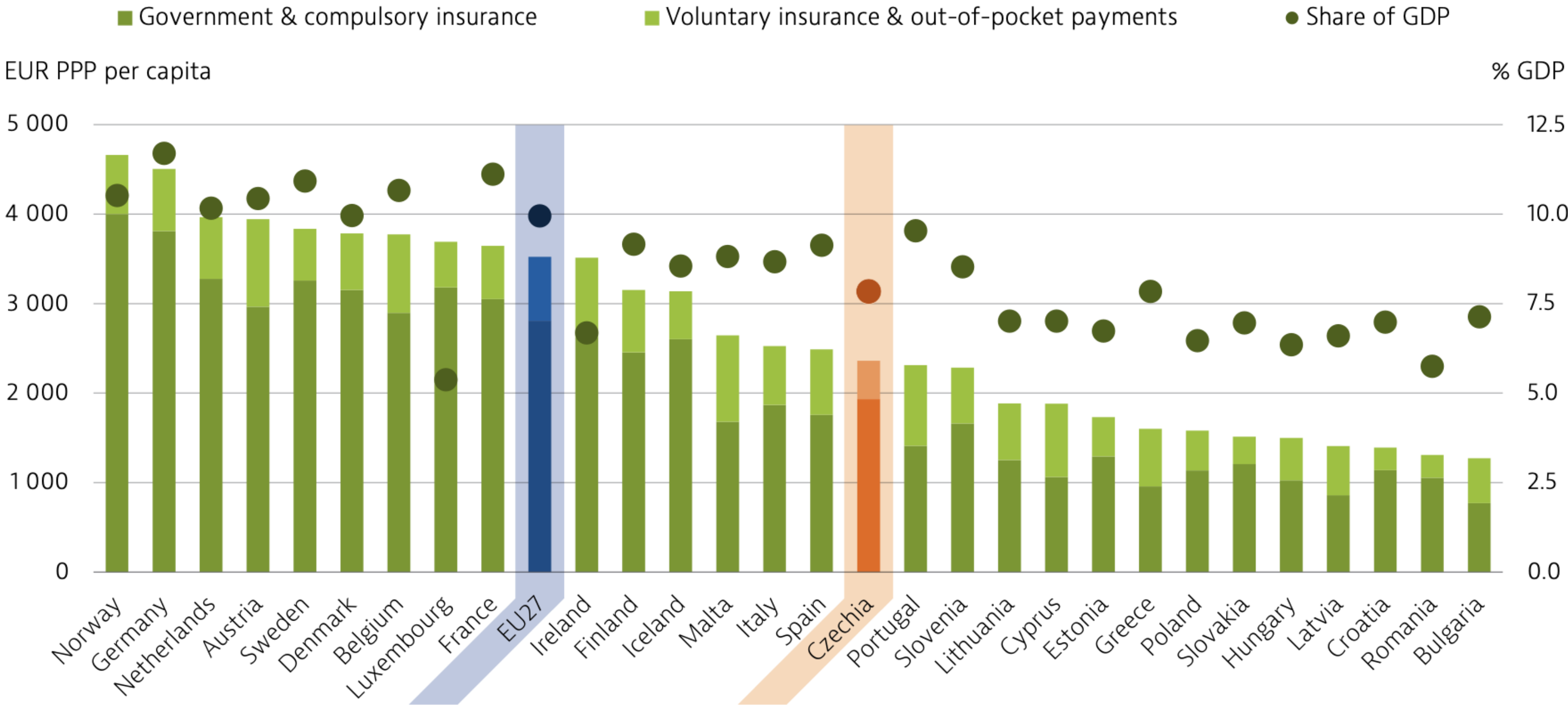

*Note: The EU average is weighted.  
 Source: OECD Health Statistics 2021 (data refer to 2019, except for Malta 2018).*

**Figure 10. Mortality from preventable and treatable causes are higher in Czechia than the EU averages**

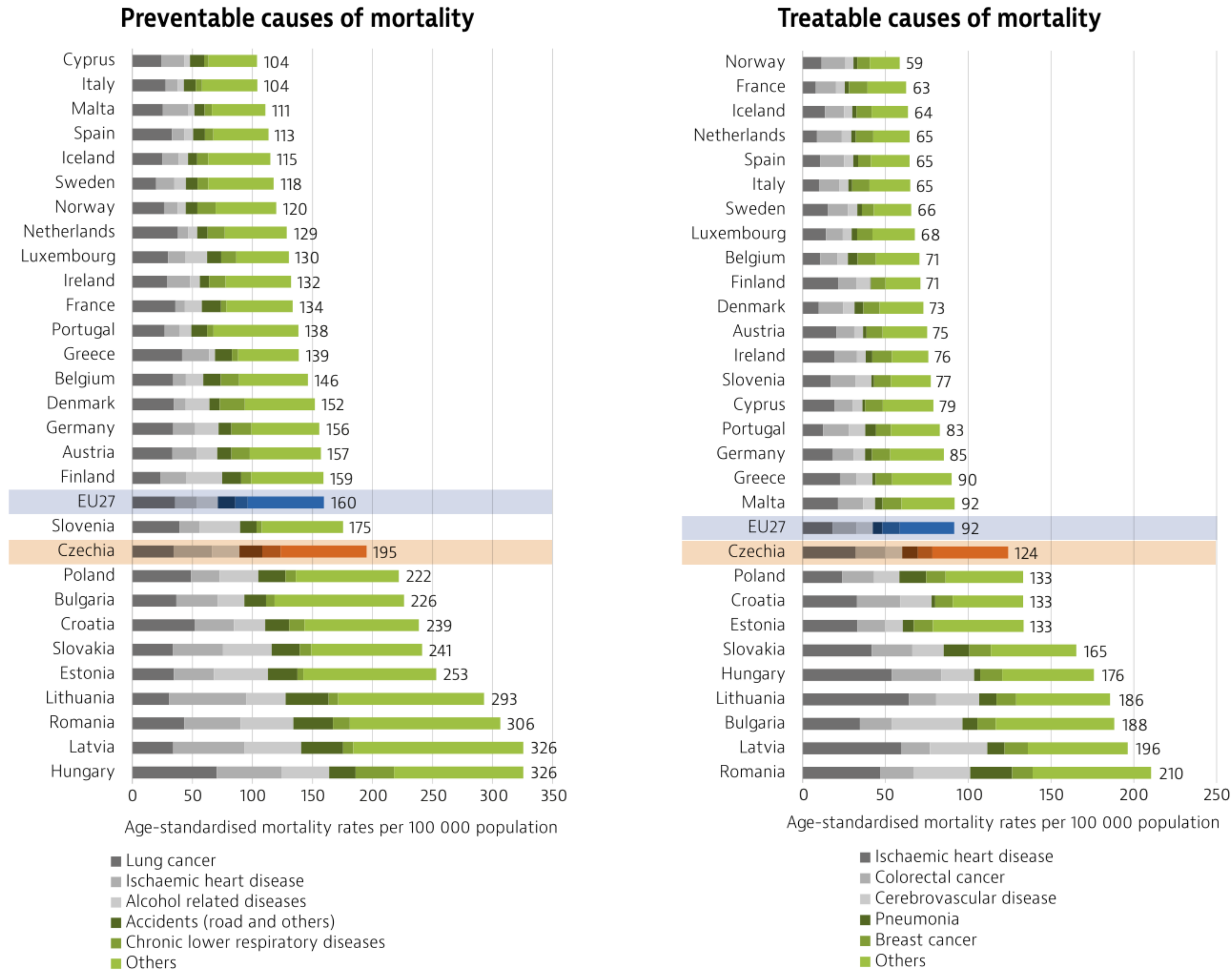

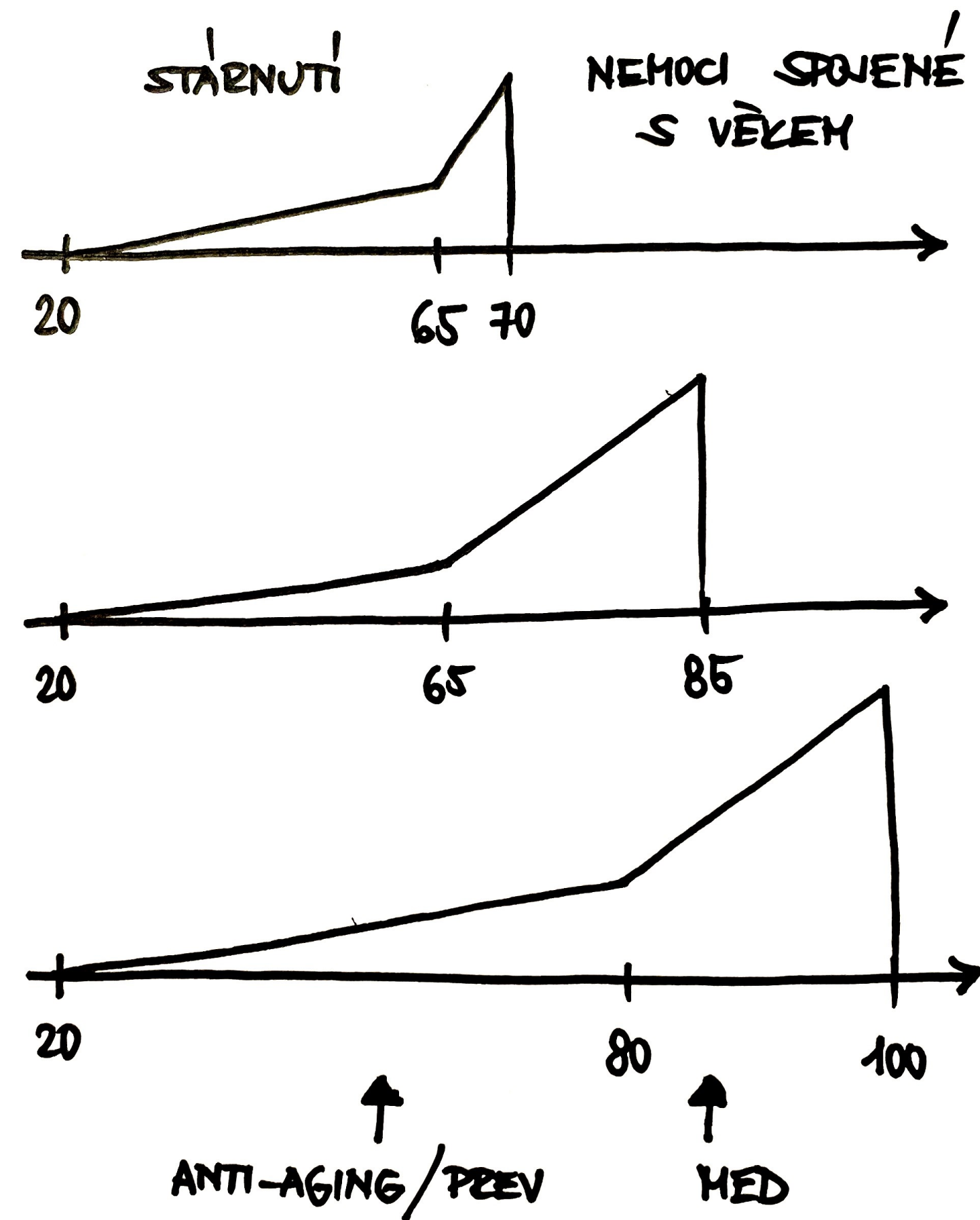



EUROPE

X



CZECH  
REPUBLIC

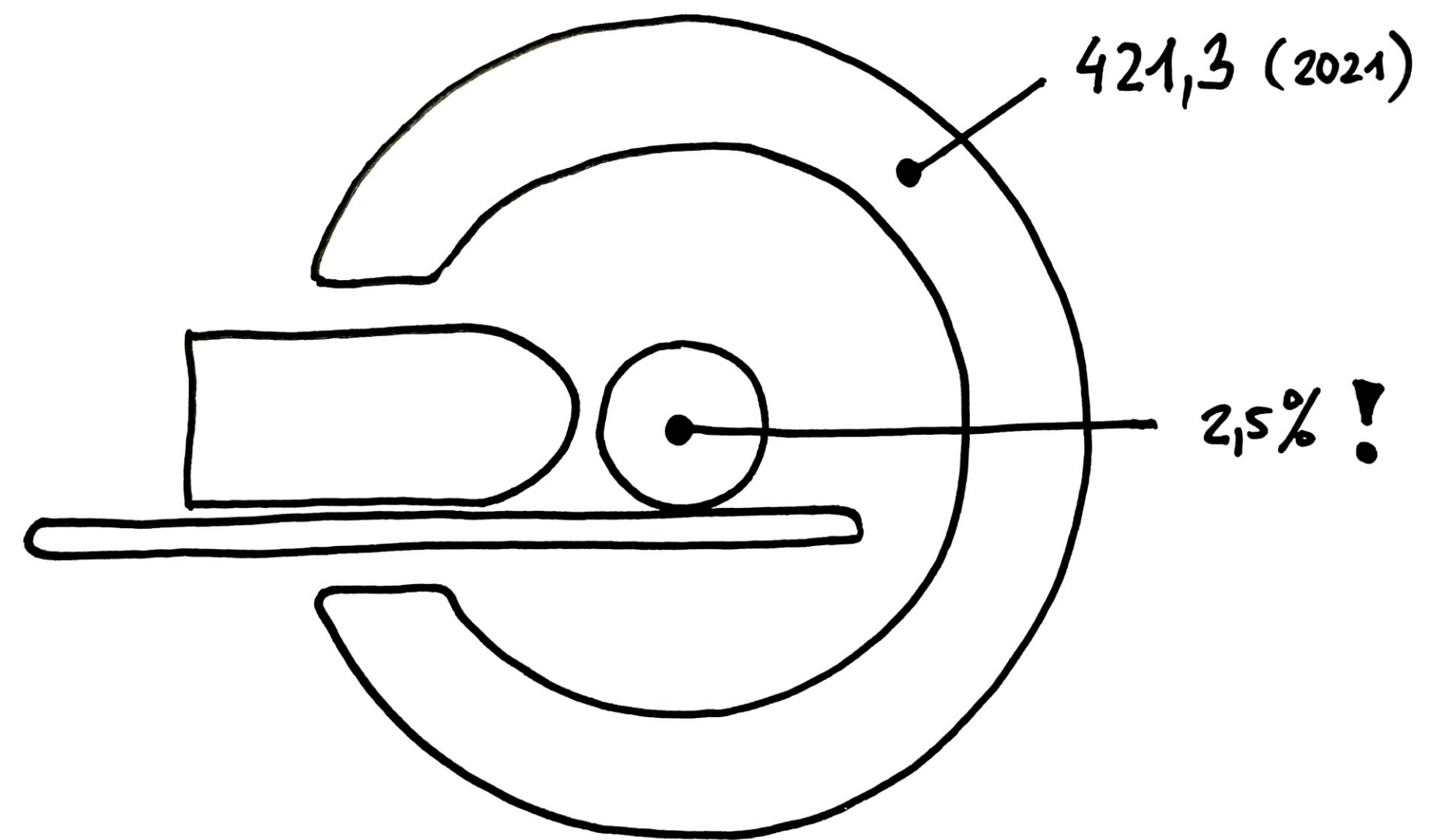

UNITED NATIONS : THE 17 GOALS

GOAL (3) Good Health & Well-Being :)

ENSURE HEALTHY LIVES AND PROMOTE WELL-BEING FOR ALL AT ALL AGES.



5P

PREDICTIVE  
PREVENTIVE  
PERSONALIZED  
PARTICIPATORY  
PERMANENT

4340

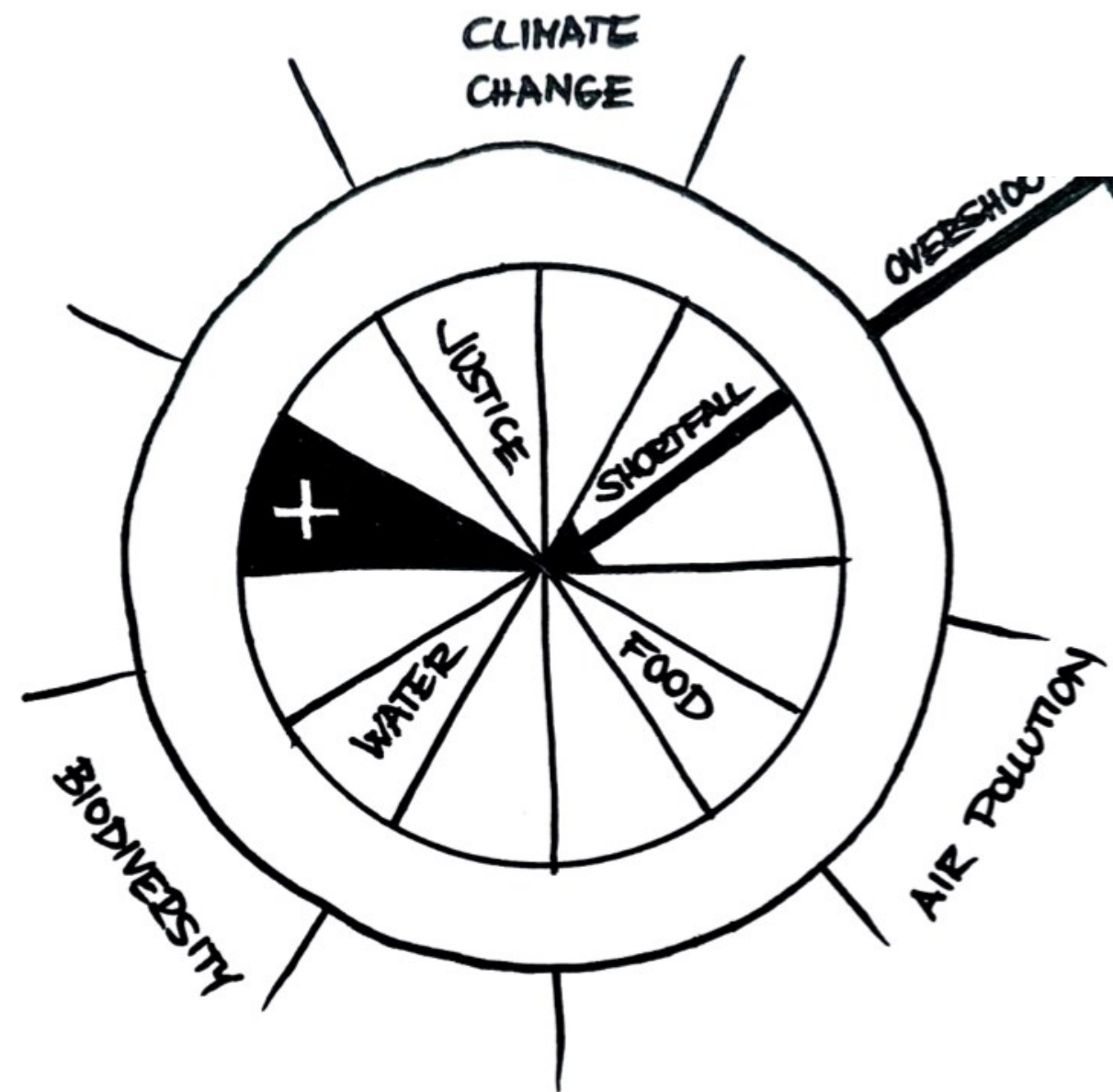
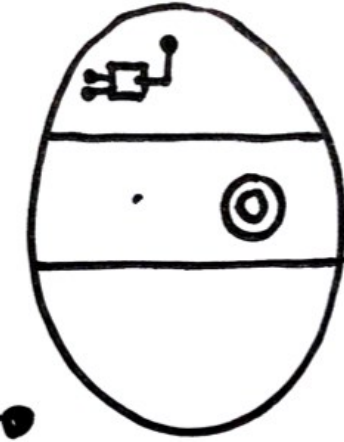

DOUGHNUT ECONOMICS BY KATE RAWORTH

**Cíl Ministra Zdraví: Zvýšíme do roku 2030 počet let ve zdraví v ČR o 5 let.**

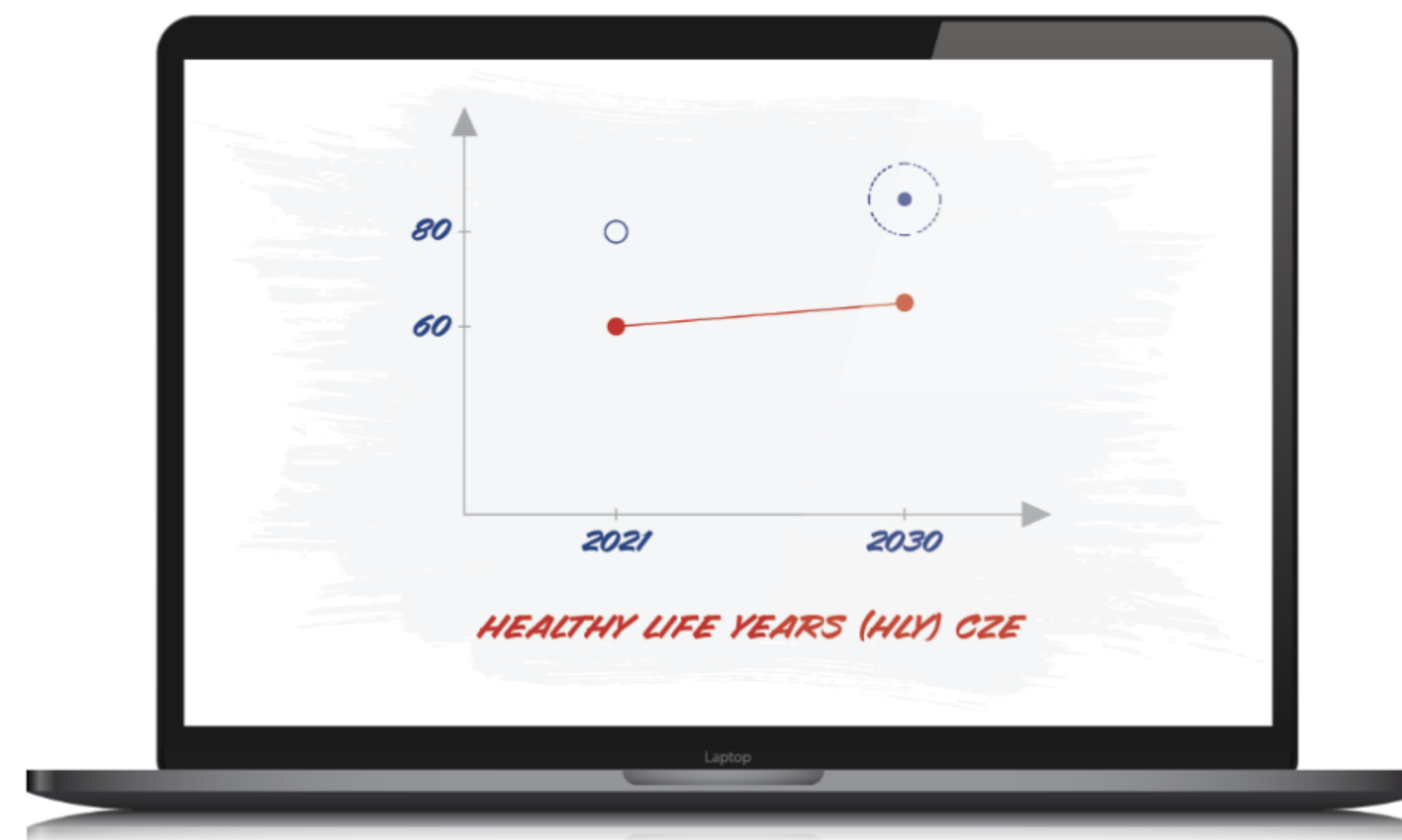





## DIGITALIZACE

Cílem je plně digitální zdravotnictví. Využívání moderních technologií tam, kde jsou nejvíce potřeba.

Například vzdálený přístup k lékaři a za splnění nejvyšších podmínek ochrany dat a v legálním rámci.



## PREVENCE

Cílem je vést populaci k odpovědnosti. “Zdraví je vaše.” Budoucí medicína bude prediktivní, personalizovaná, participativní, permanentní. O tom je prevence budoucnosti.



## FINANCE

Digitalizace má být jen prostředek, který umožňuje jednoduše a levně udržovat zdraví nebo pomoci kontrolovat chronické onemocnění. To je levnější než drahá péče.

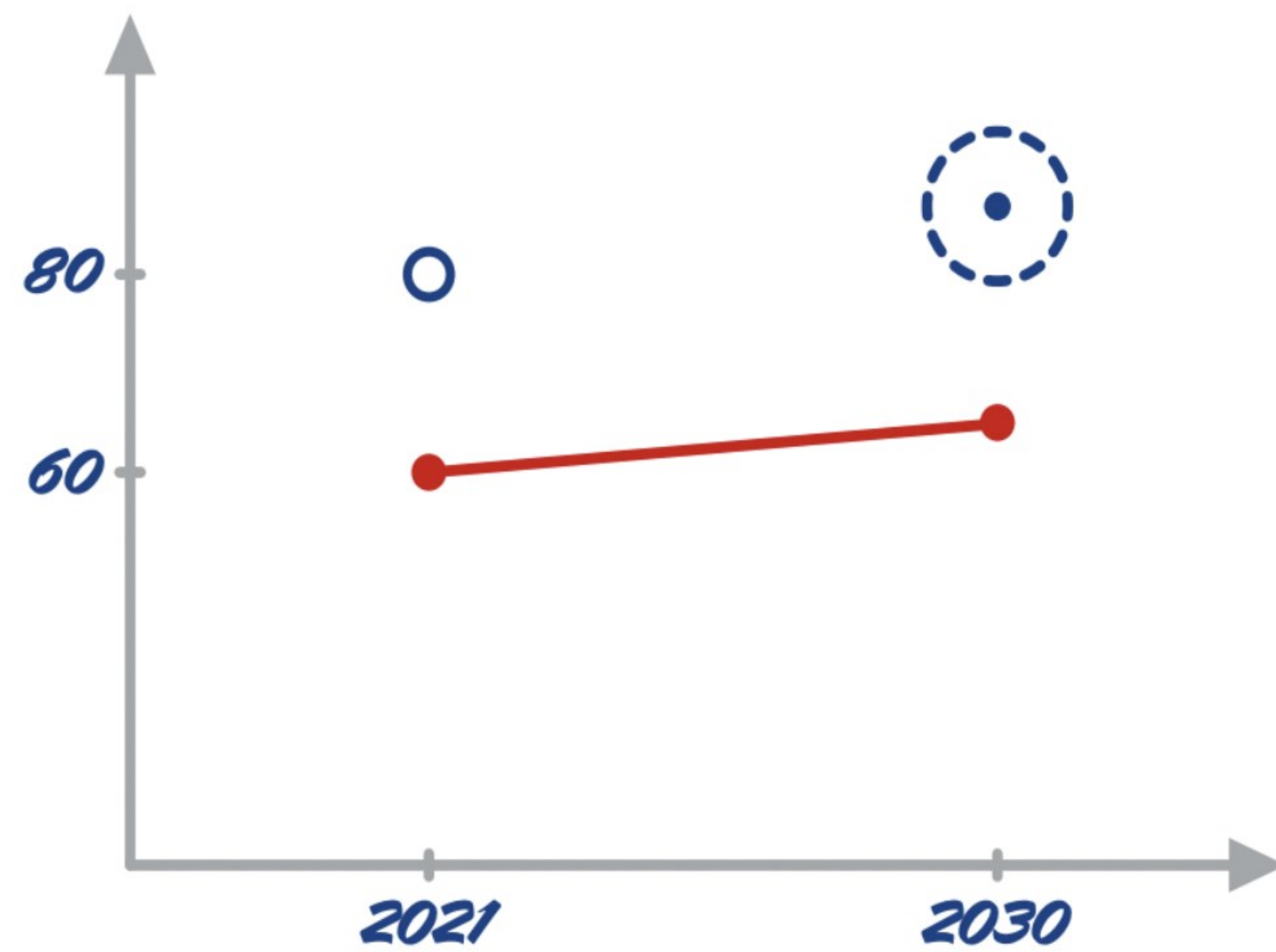

*HEALTHY LIFE YEARS (HLV) CZE*